



## SHELL SCHEME STANDS SPECIFICATIONS & GENERAL INFORMATION

The Organisers have appointed Global Experience Specialists (GES) as the Official Show service provider for GESS Dubai 2024.

Venue	Show Dates	GES Service Centre Contact Details	Order Online
DWTC, Dubai, UAE	12-14 November 2024	Phone: +971 4 885 5448 Email: <a href="mailto:gess@ges.com">gess@ges.com</a>	<a href="#">GES Online Shop</a>

GES, as the show service provider, will be responsible for all the following services:

- SHELL SCHEME STANDS:** Supply, build and onsite support of all Shell Scheme stands
- MAINS ELECTRICITY:** Power supply to Shell Scheme stands; maximum of 500watts per strand
- CARPET:** Supply of exhibition grade carpet to Shell Scheme Stands

GES can also offer the following additional services to **Shell Scheme Exhibitors**:

- FURNITURE:** Supply and installation of any additional furniture requirements
- GRAPHICS:** Printing and installation of graphics
- STAND FITTING EXTRAS:** Supply and installation of any additional stand fitting requirements
- ELECTRICAL EXTRAS:** Supply and installation of any additional electrical requirements

It is strongly recommended that orders for any of the above services are placed early to ensure securing preferred items and prompt delivery during the build-up of the show.

Exhibitors can place the order through the [GES Online Shop](#).

# GES SERVICES



The above visual is for reference only. The Shell Scheme booked with the show Organiser may look different depending on the stand size, location and orientation. Some larger stands may require additional pole support on its open sides.

## The following is included in the space rental fee for Shell Scheme stand.

- Aluminium Sodem profile structure with white forex infill panels at overall height of 3 metre
- Company name and stand number is printed in vinyl cut-out lettering
- Exhibition grade carpet

### Electrical Package (per 9sqm)

- 3 x 35W Halide Spotlights
- 1 x 3-pin UK Standard Electrical Socket

### Per stand

- 500watts power supply

### Furniture Package (per stand)

- 1 x Arc table, black (code: MT21)
- 2 x Iso chairs, black (code: MC12)
- 1 x Waste bin (code: MA10)

# SHELL SCHEME STAND PACKAGE

# SHELL SCHEME STAND STRUCTURE

- Shell scheme stand is built to an overall height of 3.00 metre height. Sodem stand wall height is 2.50 metre height. Sodem system utilising an aluminium metal framework with white forex infill panels.
- Each wall panel dimension is 1.0m width x 2.50m height including the aluminium beams and poles.
- Number of wall panels for each stand will vary on how many sides open the stand has.
- GES reserves the right to impose charges on any modifications applied to any parts of the Shell Scheme stand.
- **It is prohibited to affix nails, hooks, tacks, screws, adhesives, paint or similar items to any other part of the shell scheme stands.**
- Shell Scheme panels are reusable, and any damages will incur a fee.
- Any additional displays must be limited within the shell scheme stand space and must not exceed 2.50m height.
- However, should there be any request to display materials which exceeds the height limit of the shell scheme stand, must contact the show Organiser for permission and approval.

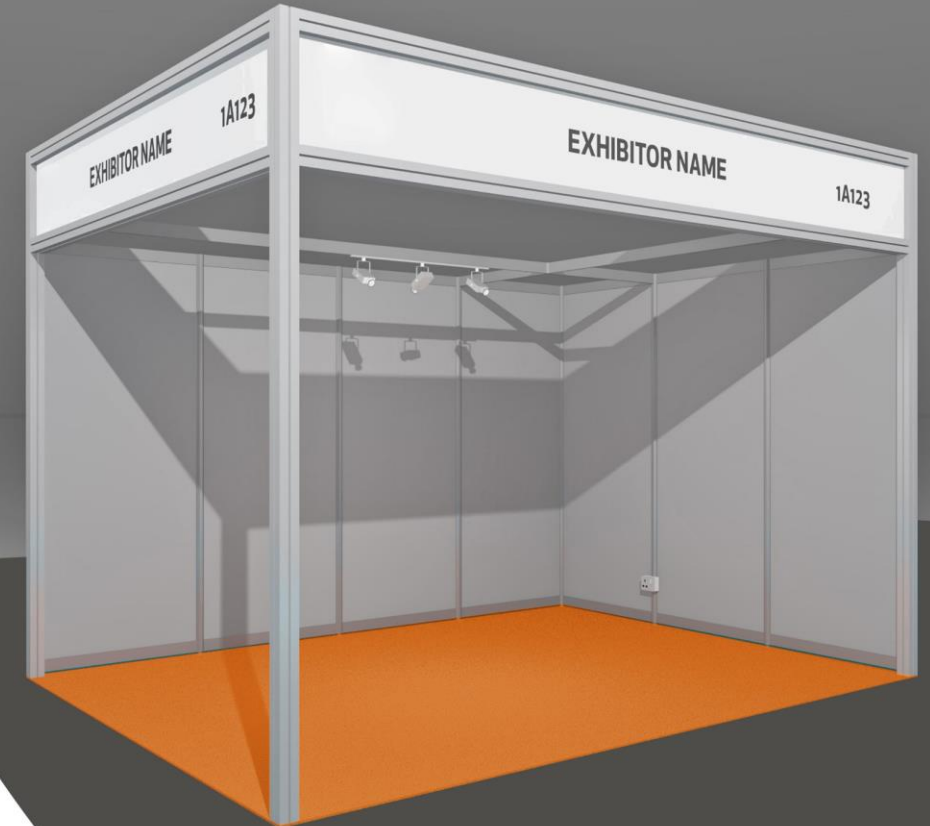

# SHELL SCHEME STAND NAMEBOARD

- Fascia panel measuring 50cm deep including frame; the number of fascia panels are dependent on the shell scheme stand size, orientation and location.
- The company name and stand number will be supplied on a standard panel fixed to the front and / or side of the shell scheme stand. **It is printed in vinyl lettering cut out at 60mm height upper case and the colour is chosen by the show Organiser.**
- The cost of all fascia panels is included in the shell scheme stand booked with the show Organiser.
- Support columns are located at the corners of the stand and at every 3 running metre fascia.
- Please complete the Nameboard Form for the name you wish to appear on your shell scheme stand and return to [gess@ges.com](mailto:gess@ges.com) before **27<sup>th</sup> October 2024** to ensure your name board is correct.
- Please type carefully or write clearly (upper or lower case) as mistakes will be charged for if they must be corrected. We restrict to 30 characters including spaces, this does not include the stand number.
- If Name board form is not submitted by the deadline date, the company name as per the Exhibitors List provided by the Organiser will be used to print for your name board(s).
- Any changes and request for re-printing that have been made due to illegible writing or incorrect typing will be charged for US\$25.00 per fascia per panel.

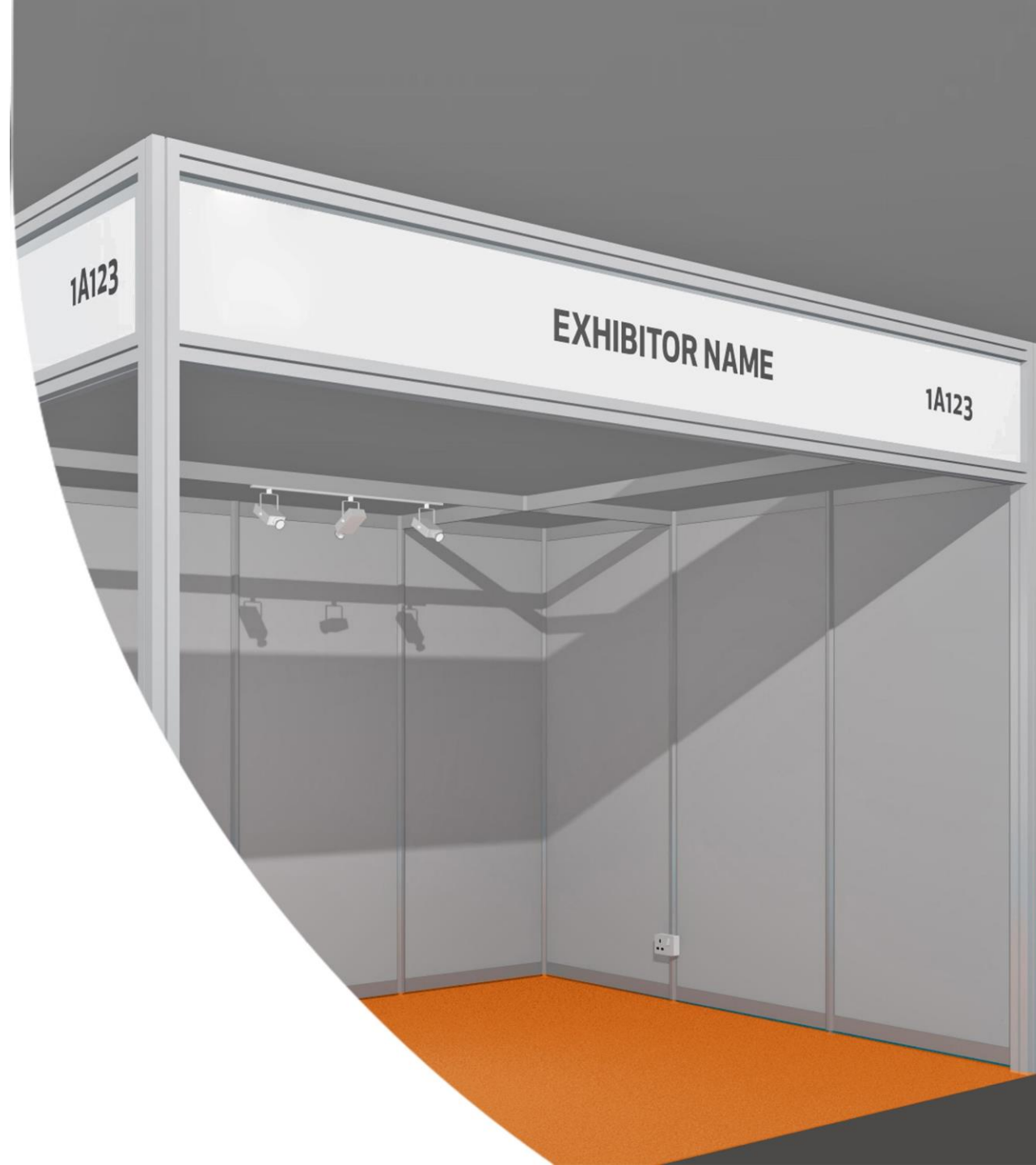

# SHELL SCHEME STAND CARPET

---

- Shell Scheme stand rental charges include exhibition grade carpet with plastic cover, installation and removal during breakdown.
- Exhibitor may opt to change a different colour or quality type carpet. However, this should be ordered separately through the [GES Online Shop](#) at an addition cost.
- It is also possible for Exhibitors to order additional flooring components such as a platform and under carpet padding. Please contact us for quotation and further information.
- **GES does not hold any liabilities for any damages (teared out or stained carpet) incurred after the installation of the carpet.**
- Please note all orders are subject to availability and Exhibitors are encouraged to place the orders before the deadline date to secure preferred items and to avoid incurring late order charges.



# SHELL SCHEME STAND FURNITURE PACKAGE

---

Shell Scheme stand includes one furniture package **per stand** space booked.

The package comprises of the following:

- 1 no. x Black Arc Table (code: MT21)
  - 2 nos. x Black Iso Chairs (code: MC12)
  - 1 no. x Waste bin (code: MA10)
- 
- Items included in the package cannot be substituted or exchange of any other items available in the furniture catalogue.
  - However, if Exhibitors require an alternative or an additional furniture items, they can place the order separately through the GES Furniture order form or the [GES Online Shop](#).
  - All orders are subject to availability and we would encourage all Exhibitors to place orders early to secure preferred items and to avoid incurring late order fees.



# SHELL SCHEME STAND ELECTRICAL PACKAGE

- Shell Scheme stand includes power supply consumption and one electrical package **per 9sqm** comprising of the following:
  - 3 x 35W halide spotlights (code: E010)
  - 1 x 3-pin UK standard socket (code: E030)

Stand Size (sqm)	35W halide spotlights	3-pin UK standard socket
0 - 17	3	1
18 - 26	6	2
27 - 35	9	3
36 - 45	12	4

- The shell scheme stand will be provided with a maximum power supply of 500 watts only **per stand**. It is sufficient for charging laptops and mobile phones, fridges, TV etc.
- Spotlights on a track are being installed on the overhead ceiling grid support of shell scheme stand.

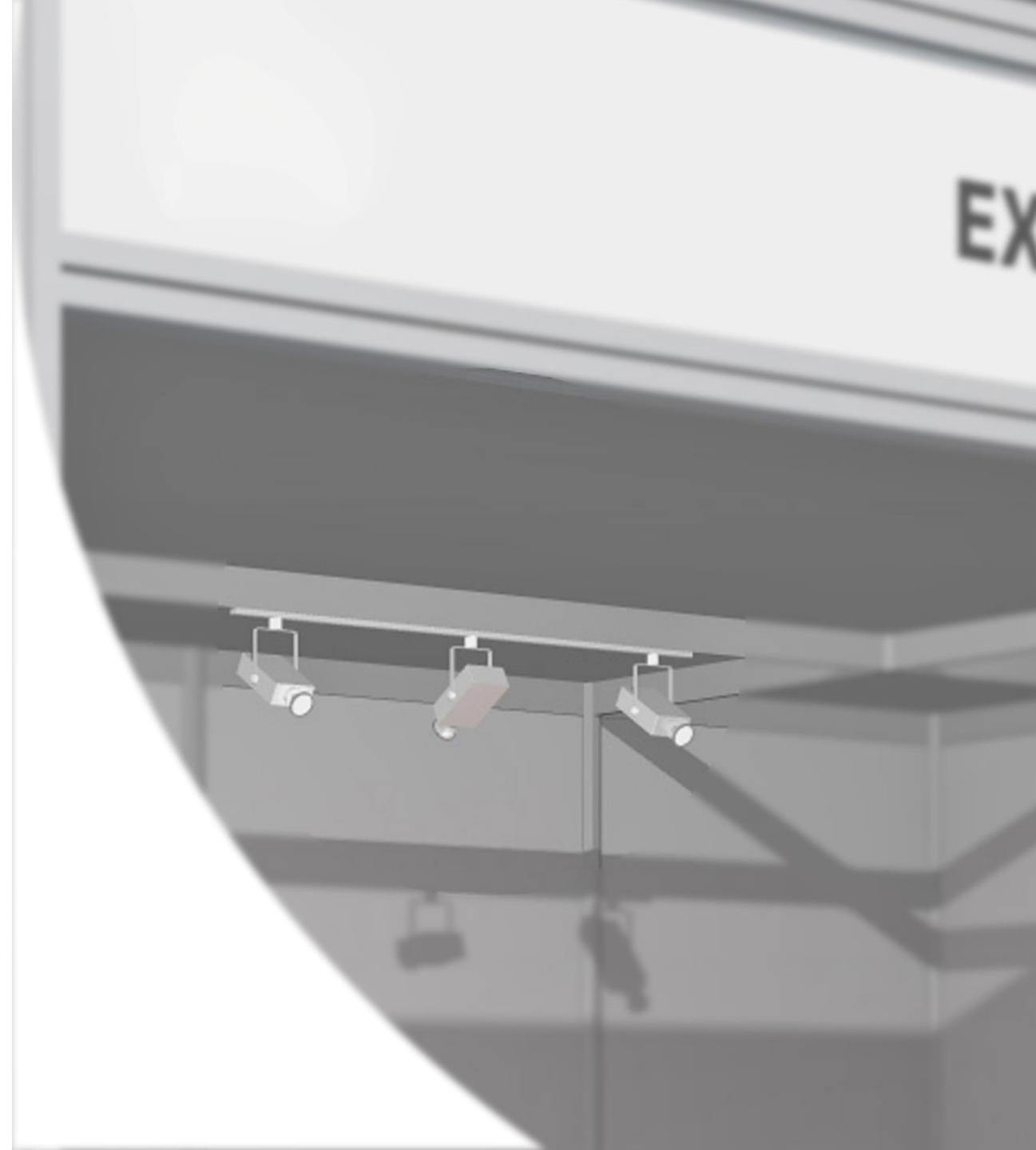



# SHELL SCHEME STAND ELECTRICAL PACKAGE

---

- If Shell Scheme Exhibitor will be building their own stand, please note that spotlights will not be provided. The installation of spotlights on a track is suitable only for the shell scheme stand structure.
- Electrical socket provided for Shell Scheme stand is a 3-pin UK standard socket. Should there be any requirement of a different type plug / socket must need to secure a multi-pin plug adaptor.
- **A completed grid plan must be submitted indicating the preferred location of the spotlights and sockets. Any socket/spotlights relocations onsite due to the incorrect grid plan submitted, will incur a surcharge.**
- Any additional electrical requirements (e.g. sockets, extension leads) can be ordered through the [GES Online Shop](#) for Shell Scheme stands.
- If stand requires power supply above 500watts or 24hr continuous power due to coffee machines and other equipments, please contact us via email for further advise and information.



# SHELL SCHEME STAND STANDFITTING EXTRAS

- Shell scheme standfitting extras e.g. storage areas, shelves, garment rails, slat and peg boards are some of the options to store or display item products. These fittings are suitable only on a shell scheme aluminium structure.
- Any shell scheme stand extras requirements can be ordered through [GES Online Shop](#).
- **Along with the order, a completed grid plan must be submitted indicating the preferred location of the items.**
- If a grid plan is not submitted, the ordered items will not be installed. Unless otherwise, the Exhibitor will visit the GES Service Desk onsite or advise via email until the build-up period to instruct their preferred locations.
- **Any onsite relocations due to incorrect grid plan submitted, will incur a surcharge.**
- For any requirements not available on the order form, please contact us via email and we will do all we can to accommodate your request.



# SHELL SCHEME STAND GRAPHICS

- As the official service provider, any graphics services should be ordered through GES.
- GES can provide graphics services to Shell Scheme stand Exhibitor such as seamless wall graphics, individual panel graphics, seamless fascia and logo, banners and other graphics solutions.
- Graphics services can be ordered through the [GES Online Shop](#) for reference of prices and service options. Prices on the order form include printing, installation and removal of graphics after the show.
- Shell Scheme Exhibitors may also contact our Graphics team for quotations and further information.

GES – Graphics Department

Tel: +971 4 885 5448

Email: [gess@ges.com](mailto:gess@ges.com)

Web: [www.GES.com](http://www.GES.com)

## Shell Scheme stand with Seamless Wall & Fascia Graphics



# SHELL SCHEME STAND GRAPHICS

- Upon confirmation of order, a high-resolution file and ready-to-print artwork must be submitted not later than 3 weeks prior to the show build.
- Please note that full payment is required in AED or USD currency 15 days prior to the show opening date. Graphics will not be printed and installed, unless 100% payment is received.
- The shell scheme stand walls and structure is property of GES.
- We encourage shell scheme stand exhibitors to place their graphics orders through GES to avoid damages of the panels.
- Any damages on the panels will be charged US\$ 200.00 per panel to the Exhibiting Company.

## Shell Scheme stand with Individual Wall Graphics & Fascia Logo



# SHELL SCHEME SPECIFICATION

For stand graphics dimensions, please contact us via email [gess@ges.com](mailto:gess@ges.com) or telephone +971 4 885 5448

## SHELL DIMENSIONS

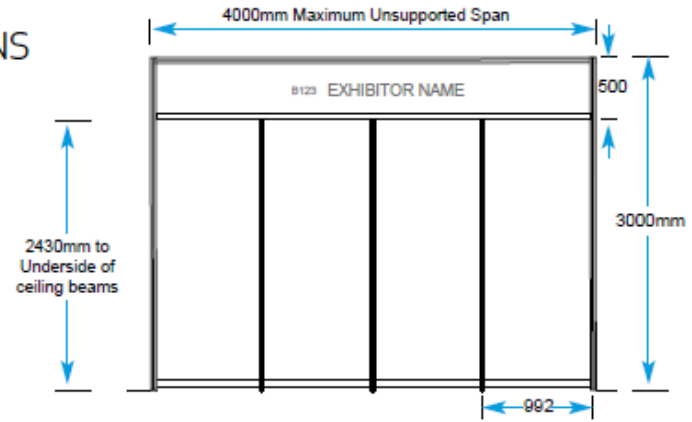

## PANEL DIMENSIONS

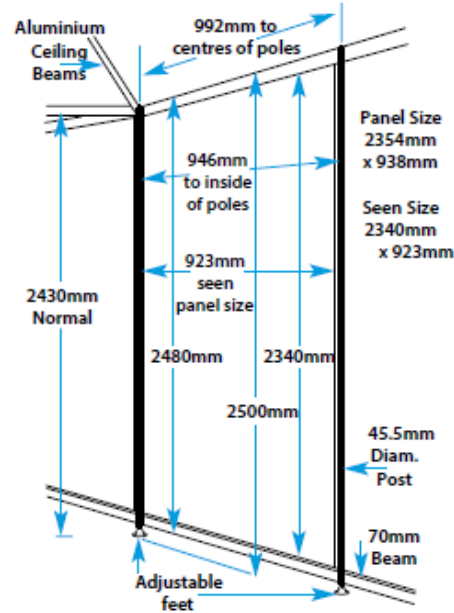

## POST SECTION

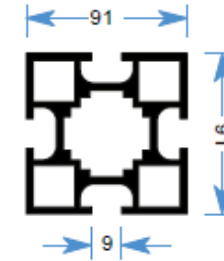

## BEAM SECTION

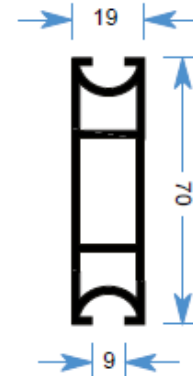

## POSTERS & PANELS

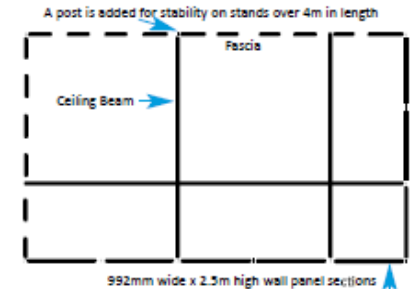
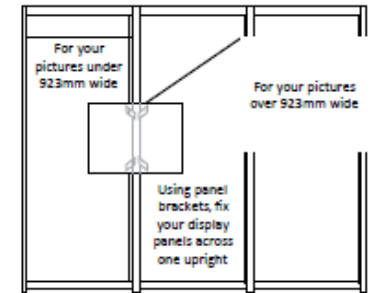

## EVENT BREAKDOWN

GES will begin to dismantle the Shell Scheme stands right after the closing of the event. We would request exhibitors to clear the stands from any display items, products and personal properties that does not belongs to GES during the breakdown.

Exhibitors are held responsible for any found damages / loss of GES properties and will be charged accordingly.

GES is not held responsible for any items that are left unattended or not taken away right after the closing of the event, whilst breakdown is ongoing.

## GENERAL QUERIES

For any queries regarding Shell Scheme stands, Space Only power supply, Exhibitor Services, payments and other concerns related to GES as the Official Stand Contractor, Exhibitors can feel free to contact GES via email [gess@ges.com](mailto:gess@ges.com) or call our **Customer Care Team at +971 4 885 5448**.

## OTHER SERVICES

Please be advised that GES is not responsible for the following services:

- Internet / WIFI
- Floral arrangements
- Rigging & Hanging Banner
- Badges / Other Passes
- Hostesses / temporary staff
- Catering
- Freight / Logistics

Please direct any queries for the above to the show Organiser who can advise and give further information.

# GENERAL INFORMATION